

Antonics-ICP 5G-Ready with MF-05 Series

high transmission quality by new MIMO
technology and cross polarization



1. Introduction

This document describes the current specifications and in addition the planned innovations in the field of radio transmission and planar antenna technology. Especially the MIMO technology and the use of multiple polarization planes in an antenna contribute a very high quality of transmission and spectral efficiency.

2. Implementation of the 5G standard

In the 5th mobile radio generation (5G) the frequency spectrum is extended. To the existing frequency bands known from GSM, UMTS and LTE the spectrum is was extended by new selective frequency ranges between 3GHz and 4GHz. With the new MF-05 series the Antonics-ICP GmbH is a **leader in the field of rail and local traffic radio applications**. The 5G antennas are **backward compatible** with the previous mobile radio standards. All previously specified cellular standards can still be used. The **flat antenna design** as well as the external mechanics of the antennas has been retained. Vehicles and existing systems can be **retrofitted without problems**.

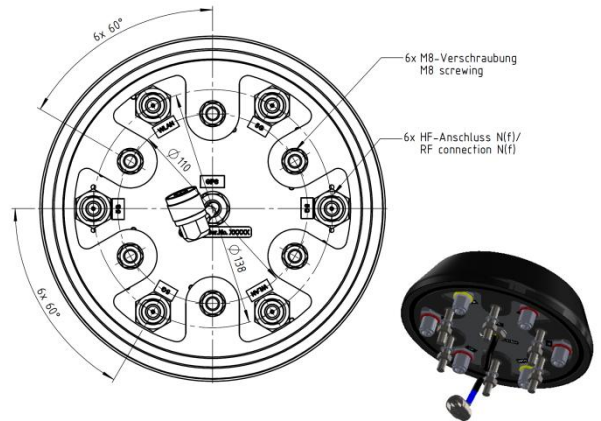

Fig. 1- Antonics-ICP GmbH 5G antenna

3. MIMO technology

Since the LTE mobile standard, more and more radio systems are equipped with MIMO technology (multiple input multiple output). Only with separated RF ports in the antenna, the benefits of MIMO technology can be used. This makes costly signal splitters superfluous. The higher MIMO technologies will be the standard in new radio systems, such as the **4x4 MIMO system**. In the antennas developed by the Antonics-ICP GmbH, MIMO systems of **different radio standards can be combined**. (Ex. [100-58-10-05.52](#) - 4x4 5G/LTE + 2x2 WLAN in one antenna.) The following advantages can be achieved by using the multi-port technology:

3.1. Spatial diversity

With the spatial diversity the transmission quality can be increased and the **dropout probability reduced**. By physically separated RF ports within the antenna, signal loss through signal superposition and cancellations can be avoided. The same signal is sent on all ports. The port with the highest signal strength is selected by the system automatically. This mechanism is also called **interference suppression**.

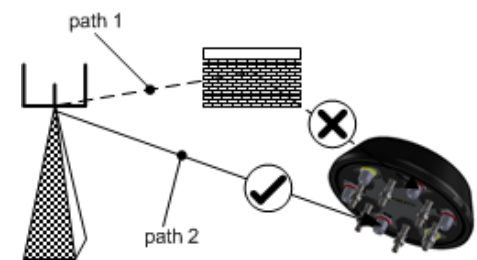

Fig. 2 - Spatial diversity at multipath and signal superposition

3.2. Multiplex diversity

Multiplex diversity can increase the data rate in a system. Depending on the number of RF ports, the corresponding data streams are received and reconstructed separately. With this method it is possible to **increase the data rate in proportion to the number of ports**.

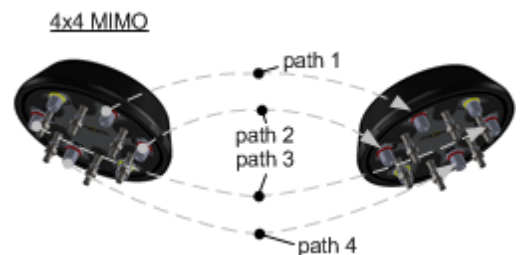

Fig. 3 - Multiplex diversity with four separated transmission streams

3.3. ECC (Envelope Correlation Coefficient)

A low ECC close to 0 is essential for a low-loss and effective MIMO system. This value determines the mutual influence of the ports within an antenna. A value of "1" indicates a complete dependence of the internal antenna radiators. "0" indicates a complete independence. Fig. 4 and Fig 5 show the ECC of the 5G MF-05 antenna series. The values of the ECC

are below 0,2 for 5G/LTE and **below 0,05 on average**. The radiators within the antenna thus have only a very low interdependence. This condition is ideal for a MIMO system.

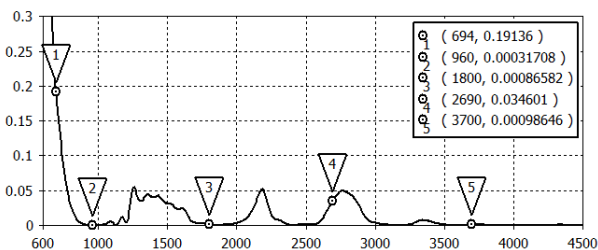

Fig. 4 - ECC for 5G/LTE (MF-05 series)

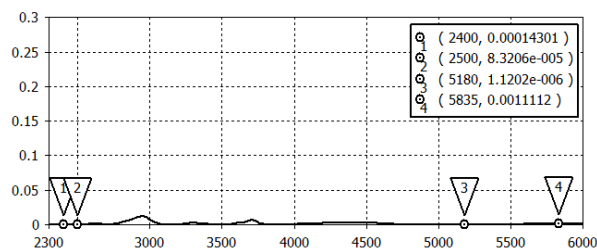

Fig. 5 - ECC for WLAN (MF-05 series)

4. Polarization

Due to their design, antennas may prefer certain polarization planes, independent of the radio signal. Conventional antennas have in general only a vertical or a horizontal polarization plane. In contrast the antennas of the Antonics-ICP GmbH, especially in mobile and WLAN use two polarization planes. Two perpendicular polarization planes are also called cross polarization.

4.1. Polarization planes

The radiation characteristic of an antenna can be mapped in a 3D far field diagram or a 2D directional radiation diagram with the corresponding antenna gain. These diagrams show in general the absolute radiation characteristic in which the gain of all polarization planes is included. The absolute diagram can then be split into the different polarization planes. One distinguishes mainly in vertical and horizontal polarization. Fig. 6 to Fig. 8 shows an example of the far field of a vertically polarized antenna. The absolute polarization diagram is almost identical to the vertical polarization diagram. The reception of signals in the horizontal polarization plane is not possible. If the vertical and horizontal polarization planes are equally distributed, as shown in Fig. 9 to Fig. 11, it is called cross polarization. Cross polarization has the advantage that **on two types of polarization can be transmitted**. If a vertically polarized signal is influenced by reflections, scattering or diffraction, the original polarization plane is changed, a large power loss occurs on the vertically polarized receiving antenna.

4.2. Polarization diversity

By using cross polarized antennas, the received power can be increased instead of using one polarization plane. (vertical or horizontal) The antennas for mobile radio and WLAN applications of the Antonics-ICP GmbH include radiators which are vertically and horizontally polarized (cross polarized). If the polarization is deflected by degradation effects in the radio channel, only small losses are caused during the transmission.

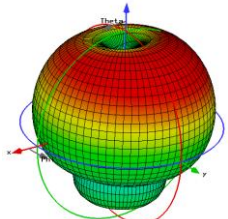
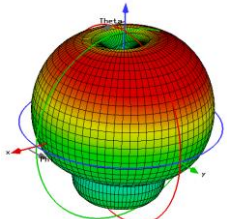
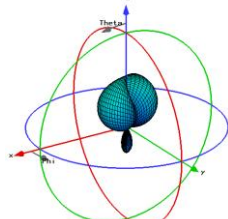
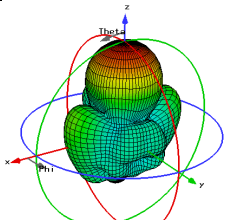
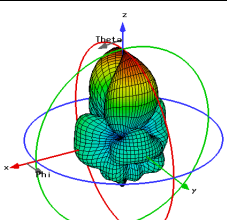
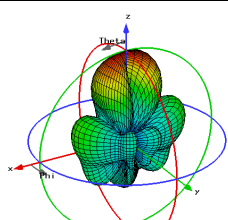
| | <u>absolute polarization</u> | <u>vertical polarization</u> | <u>horizontal polarization</u> |
|-----------------------------------|--|--|--|
| vertical polarized antenna |  <p>Abb. 1 - absolute</p> |  <p>Abb. 2 - vertical</p> |  <p>Abb. 3 - horizontal</p> |
| crosspolarized antenna |  <p>Abb. 4 - absolute</p> |  <p>Abb. 5 - vertical</p> |  <p>Abb. 6 - horizontal</p> |

4.3. Loss by polarization mismatch

If the transmit and receiving antennas in a system are not matched to each other, polarization loss may occur until to the complete fail of the transmission. In Tab. 1 the respective polarization losses are plotted to each other. The same polarization planes of transmit and receiving antenna results in a lossless system. (0dB = no loss) If the polarization planes are perpendicular to each other, the result is the complete reception interference. (20dB = signal loss of at least 99%) Cross polarization offers the advantage that there is always a very high signal power, even if the polarization is incorrectly adjusted.

| Polarization | vertical ↑ | horizontal → | circular right ↻ (rhcp) | circular left ↺ (lhcp) | crosspolar (+45°/-45°) ✕ |
|---------------------------|---------------|-----------------|-------------------------------|------------------------------|--------------------------------|
| vertical | 0 dB | 20 dB to ∞ dB | 3 dB | 3 dB | 1,25 dB |
| horizontal | 20 dB to ∞ dB | 0 dB | 3 dB | 3 dB | 1,25 dB |
| circular right | 3 dB | 3 dB | 0 dB | 20 dB to ∞ dB | 1,25 dB |
| circular left | 3 dB | 3 dB | 20 dB to ∞ dB | 0 dB | 1,25 dB |
| crosspolar (+45°/-45°) | 1,25 dB | 1,25 dB | 1,25 dB | 1,25 dB | 0 dB |

Tab. 1 - Loss by polarization mismatch



ANTONICS-ICP GmbH • Ameisenweg 5 • 16727 Velten
 Telefon +49 3304 25 42 04 • Telefax +49 3304 25 43 48 • HRB 7807NP, Neuruppin
 Internet: <http://www.antonics.de> • E-Mail: info@antonics.de

Sofern nicht ausdrücklich etwas Anderweitiges vereinbart wird, kann keinerlei Garantie für die Eignung des Materials für einen bestimmten Anwendungszweck übernommen werden. Es ist Sache des Käufers, ausreichend zu prüfen, ob sich das Material für seine Zwecke eignet, und das volle Risiko für die Verwendung des Materials zu übernehmen. Antonics-ICP übernimmt keine Haftung für die mangelhafte oder fehlerhafte Montage von Antennen, insbesondere nicht, wenn den Anweisungen der vorliegenden Montagehilfe nicht oder nur unzureichend Folge geleistet wird. Die Montage ist nur von Fachpersonal mit geeigneten Qualifikationen durchzuführen. Desweiteren wird keine Haftung für Folgeschäden an Antennen und/oder Fahrzeug übernommen, die auf eine fehlerhafte Montage zurückzuführen sind. Sollten konkrete Fragestellungen nicht ausreichend beantwortet oder unklar sein, kontaktieren Sie uns bitte rechtzeitig. Wir unterstützen unsere Kunden gern durch persönlichen [Support](#).
 Trotz aller Sorgfalt bei der Erstellung dieses Dokumentes können sich Daten inzwischen verändert haben. Eine Haftung oder Garantie für die Aktualität, Richtigkeit und Vollständigkeit der zur Verfügung gestellten Informationen kann daher nicht übernommen werden. Desweiteren behält sich die Antonics-ICP GmbH das Recht vor, Änderungen oder Ergänzungen der bereitgestellten Informationen vorzunehmen. Für etwaige Fehler wird keine Haftung übernommen.

Unless expressly otherwise agreed, no guarantee regarding the suitability of the material for a particular application can be granted. It is up to the buyer to adequately consider whether the material is suitable for his purposes, and to assume the entire risk of the use of the material. Antonics-ICP takes no liability for defective or incorrect installation of antennas, especially not if the instructions given in this installation were inadequately or not followed up. The installation must be carried out only by qualified personnel with suitable qualifications. Furthermore no liability for consequential damage to antennas and / or the vehicle is taken, which are due to incorrect installation. If concrete problems are not sufficiently answered or stay unclear, please contact us in time. We support our customers by our personal [support service](#).
 Despite all the care taken in the preparation of this document, some information may have changed. A liability or guarantee for the topicality, correctness and completeness of the information provided cannot therefore be accepted. Furthermore, the Antonics-ICP GmbH reserves the right to change or supplement the information provided. No liability is accepted for any errors.